



## INSTALLATION AND SETUP GUIDE



**V-6012WB**  
**Wi-Fi Bullet Network Camera**

# GET STARTED

The V-6012WB is a 2 Megapixel indoor/outdoor video camera that allows users to view live and recorded HD video clips in Virtual Keypad™.

To activate the camera, you need an active Dealer Admin account at [dealer.securecomwireless.com](http://dealer.securecomwireless.com).

## Compatibility

- ▶ Any active Virtual Keypad account with **Cameras and NVRs** enabled
- ▶ Dealer Admin™ must be used to connect the camera to Wi-Fi

## What's Included

- ▶ One V-6012WB Camera with Mounting Plate
- ▶ 12 VDC Power Supply
- ▶ Mounting Template
- ▶ Hardware Pack
- ▶ One 32 GB SD Card

## Procedure

This guide walks you through the required steps needed to install a V-6012WB camera. They are:

1. Wire the camera.
2. Connect the camera to Wi-Fi.
3. Mount the camera.
4. Configure motion detection regions.

# WIRE THE CAMERA

Refer to Figure 1 for the location of the power and Ethernet connectors.

## **Standard Power Connection**

To use this camera with a Wi-Fi connection, connect a 12 VDC power source to the camera power connector. You can optionally connect a network cable to the camera Ethernet connector. For compatible power supplies, refer to “Accessories”.

 **Note:** The V-6012WB does not support POE.

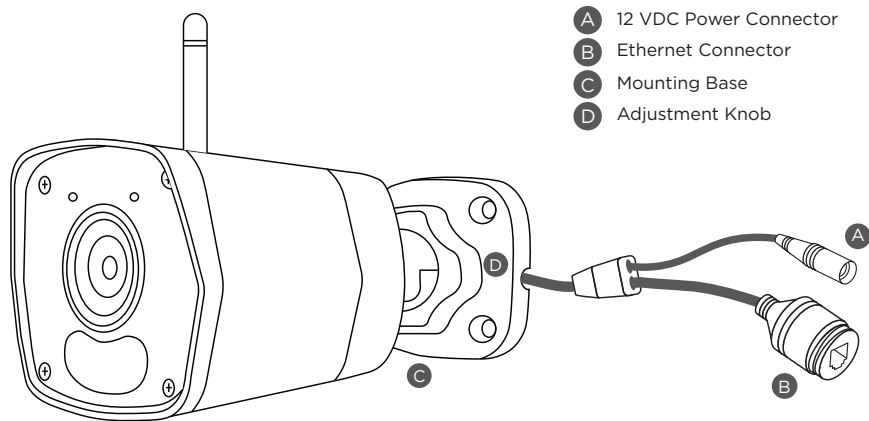

**Figure 1: Camera Power Details**

# CONNECT THE CAMERA TO WI-FI

Ensure that you know the Wi-Fi network and password that you wish to connect the camera to.

1. Log into Dealer Admin (dealer.securecomwireless.com) and select the customer and system you want to add the camera to. Select **Edit**.
2. In **Video**, go to Cameras & NVR, and select the checkbox to enable cameras. Use the drop down box to select the **Number of Cameras**.
3. Select **Save**. You will be directed back to System Information.
4. In **Video**, tap the **+ Camera** button.
5. A pop-up displays, prompting you to select a connection type. Select **Wi-Fi**.
6. Enter the **Wi-Fi SSID** and **Password**. Select **Next**.
7. Facing the provided QR code, hold the camera 6 to 12 inches away from the device. The camera reads the QR Code and attempts to connect to the Wi-Fi network. Use the chart below to diagnose whether the connection is successfully established.

STATUS	INDICATOR
Camera is starting up	Steady red
Ready for Wi-Fi connection	Flashing green (around once every second)
Wi-Fi connection successful	Steady green
Wi-Fi connection failed	Flashing red (around once every second)

 **Note:** If the network connection fails, press and hold the reset button for 10 seconds until the camera restarts, then try again.

8. Once the connection is successful, select **Next**.
9. Enter the camera **MAC Address**. Select **Next**.
10. Wait for the camera to be added to the system in Dealer Admin. This may take several minutes.

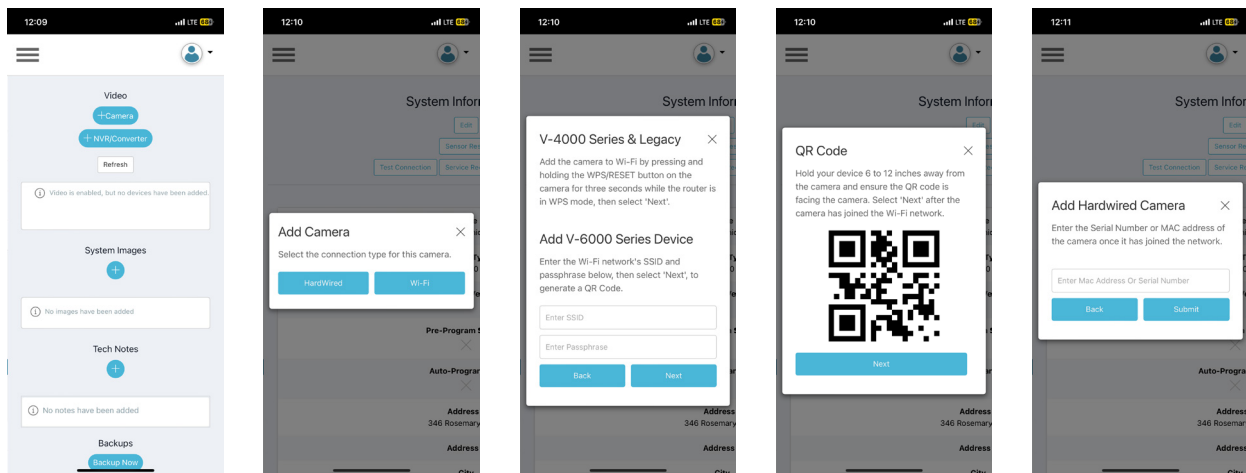

**Figure 2: Connect the Camera to Wi-Fi with Dealer Admin**

11. Enter a **Name** for the camera.
12. In **Advanced**, you can configure the following basic settings:
  - ▶ Video Quality
  - ▶ Flip Image
  - ▶ Record on Alarm
  - ▶ Allow End User Setting
  - ▶ Time Zone
  - ▶ Observe DST
13. Select **Save**.

 **Note:** If you do not have a Dealer Admin login, on the log in page, select **Generate QR Code** and follow steps 6-8. Call your Dealer Admin Administrator to add the camera to a system using the MAC address.

# MOUNT THE CAMERA

## *Standard Wall or Ceiling Mount*

Refer to Figure 3 when mounting the camera.

1. Place the mounting template at the location you want to mount the camera.
2. Drill holes into the mounting template.
3. Turn the adjustment knob counterclockwise to loosen the camera.
4. Use the included screws and wall anchors to mount the camera base to a wall or ceiling.
5. Turn the adjustment knob clockwise to tighten the camera.



**Note:** The mounting surface must be capable of holding five times the camera's weight.

## *Adjust the Camera*

Refer to Figure 4 when adjusting the camera.

1. Turn the adjustment knob counterclockwise to loosen the camera.
2. Adjust the pan, tilt, and camera rotation angle as needed.
3. Turn the adjustment knob clockwise to tighten the camera.

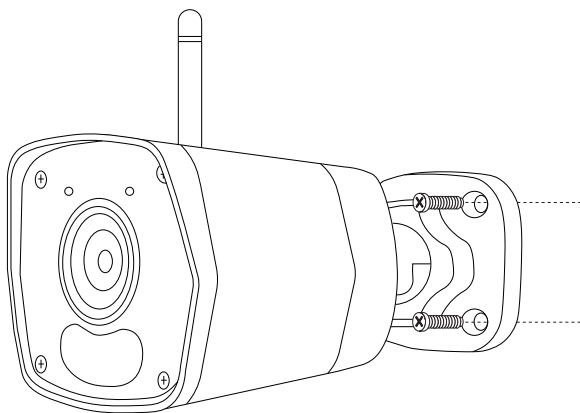

**Figure 3: Mount the Camera**

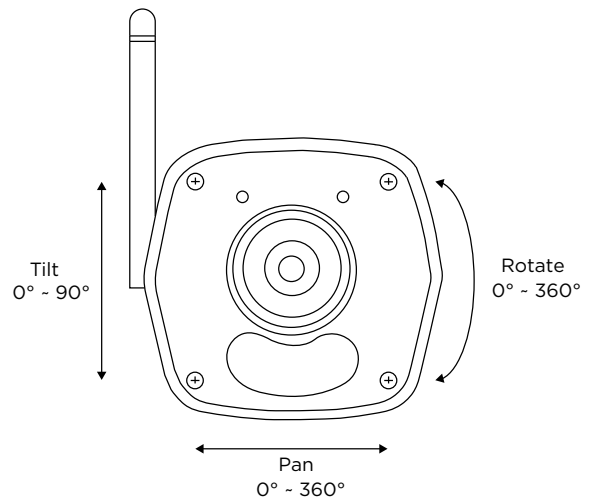

**Figure 4: Adjust the Camera**

# CONFIGURE MOTION DETECTION REGIONS

After mounting the camera, configure the camera motion detection regions in Dealer Admin.

1. Navigate to Dealer Admin and select the camera you want to add a motion detection region to.

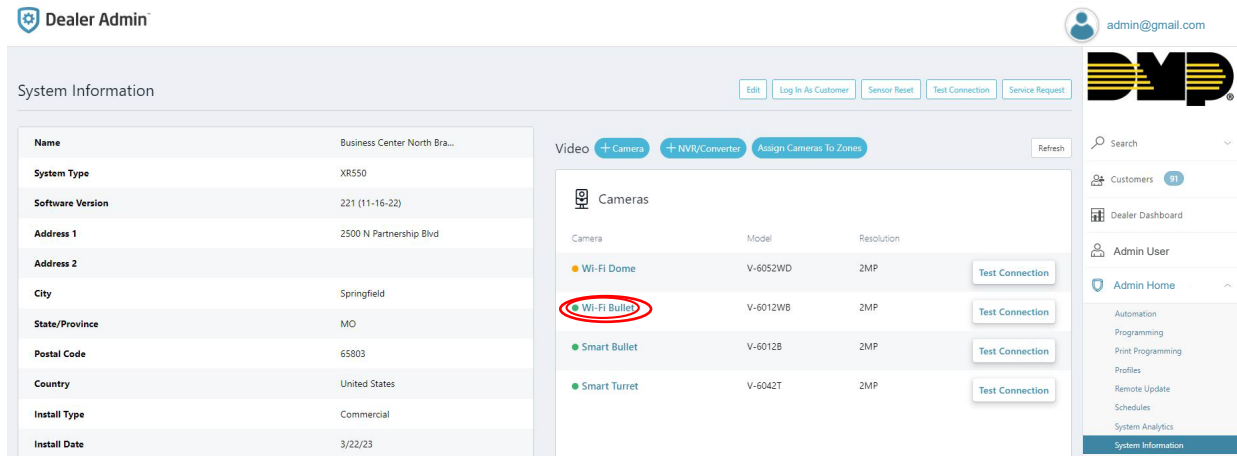

Figure 5: Select a V-6000 Camera in Dealer Admin

2. In the **Regions & Analytics** section, select **+Region** and give it a **Name**.
3. Select the sensitivity of the region. Default is **50**.
4. Dealer Admin will populate a 4-point rectangle in camera view screen. Click and drag an endpoint to change the size of the region.

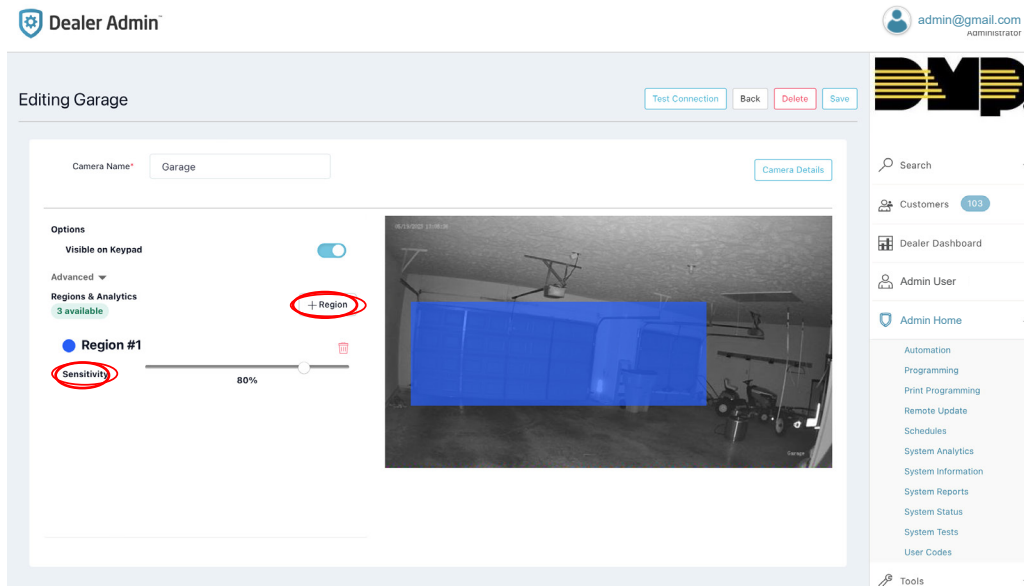

Figure 6: Configure a Motion Detection Region in Dealer Admin

# ADDITIONAL INFORMATION

## *Creating Detection Regions and Video Analytic Regions in Virtual Keypad*

In Virtual Keypad, end users can create detection regions and video analytic regions. Refer to [Virtual Keypad App Help](#) and [VirtualKeypad.com Help](#) for more information.

## *Video Privacy in Dealer Admin and Virtual Keypad*

In Virtual Keypad, end users can choose to allow video access to technicians and dealers. When video access is enabled, all Administrator level app users will receive a notification email. To enable video access, follow the steps below.

1. Navigate to Virtual Keypad.
2. Go to **Settings** and select **Video Privacy**.
3. Use the toggle to grant technicians and dealers unlimited access to the video feed. Use the **Grant Access** button to give temporary access. The default is 12 hours, although access can be revoked instantly by pressing the **Revoke Access** button.



**Note:** All cameras brought online will immediately be granted access to the video feed for 12 hours.

## *Replace the SD Card*

Refer to Figure 7 for the location of the SD card slot.

1. Power down the camera. Replacing the SD card with the camera powered on can cause issues with the camera and SD card.
2. Locate the replacement SD card and place it to the side.
3. Remove the cover on the bottom of the camera.
4. Remove the original SD card, then insert the replacement SD card into the slot.
5. Reattach the cover.

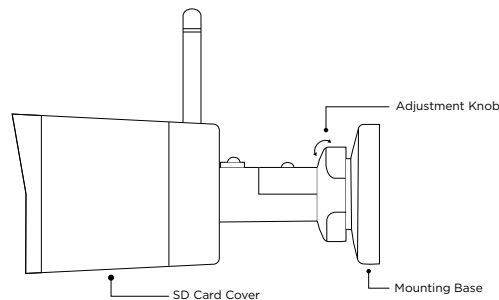

**Figure 7: Camera Details**

# ORDERING INFORMATION

V-6012WB                      2 MP Wi-Fi Bullet Network Camera

## **Accessories**

V-12V-PS                      Camera 12V 2A Plug In Power Supply

V-SD64G                      64 GB Replacement SD Card

# CERTIFICATIONS

- ▶ FCC Part 15 Registration ID: CCK-V6012WB
- ▶ Industry Canada: 5251A-V6012WB

# SPECIFICATIONS

## Sensor and Lens

Image Sensor 2 MP, 1/2.8" CMOS

## Network

Protocols IPv4

## Wi-Fi

Wireless Standards IEEE 802.11b/g/n

Frequency Range 2.4 GHz ~ 2.4835 GHz

Frequency Bandwidth 20 MHz Support

## Storage

On-Board Storage 32 GB SD card installed (Supports up to 128 GB)

## Hardware

Power Consumption

12 VDC Max 4.0 W

Weight 0.55 lbs (0.25 kg)

Dimensions 6.8" x 3" x 2.8"  
(17.2 cm x 7.6 cm 7.2 cm)

Housing Material Metal + Plastic

## Environmental

Operating Temperature -22°F to 140°F (-30°C to 60°C)

Operating Humidity Less than 95% RH, non-condensing

## FCC Information

This device complies with Part 15 of the FCC Rules. Operation is subject to the following two conditions:

1. This device may not cause harmful interference, and
2. This device must accept any interference received, including interference that may cause undesired operation.

Changes or modifications made by the user and not expressly approved by the party responsible for compliance could void the user's authority to operate the equipment.

 **Note:** This equipment has been tested and found to comply with the limits for a Class B digital device, pursuant to part 15 of the FCC Rules. These limits are designed to provide reasonable protection against harmful interference in a residential installation. This equipment generates, uses and can radiate radio frequency energy and, if not installed and used in accordance with the instructions, may cause harmful interference to radio communications. However, there is no guarantee that interference will not occur in a particular installation. If this equipment does cause harmful interference to radio or television reception, which can be determined by turning the equipment off and on, the user is encouraged to try to correct the interference by one or more of the following measures:

- Reorient or relocate the receiving antenna.
- Increase the separation between the equipment and receiver.
- Connect the equipment into an outlet on a circuit different from that to which the receiver is connected.
- Consult the dealer or an experienced radio/TV technician for help.

## Industry Canada Information

This device complies with Industry Canada License-exempt RSS standard(s). Operation is subject to the following two conditions:

1. This device may not cause interference, and
2. This device must accept any interference, including interference that may cause undesired operation of the device.

Le présent appareil est conforme aux CNR d'Industrie Canada applicables aux appareils radio exempts de licence. L'exploitation est autorisée aux deux conditions suivantes:

1. l'appareil ne doit pas produire de brouillage, et
2. l'utilisateur de l'appareil doit accepter tout brouillage radioélectrique subi, même si le brouillage est susceptible d'en compromettre le fonctionnement.



Designed, engineered, and  
manufactured in Springfield, MO  
using U.S. and global components.

LT-2734 25012

© 2025

INTRUSION • FIRE • ACCESS • NETWORKS

2500 North Partnership Boulevard  
Springfield, Missouri 65803-8877

800.641.4282 | DMP.com