

STI Euro Stopper® Multi Kit



Optional Integral
Sounder

Break Seal Facility
Left or Right
Installation Option

Optional Wireless

PRODUCT OVERVIEW

Protective cover helps prevent malicious or accidental false fire alarms. This newly styled protective cover enhances the Stopper® range, which has helped prevent false fire alarms around the world for decades, without restricting legitimate operation of devices such as fire alarm break glass call points. Sleeker and less intrusive in its design, this compact device incorporates the existing features of the Stopper but is now visibly smaller. The new hinge arrangement increases the durability, strength and quality of this essential protective cover. Ideal for schools, colleges, hospitals, nursing homes, hotels and all public buildings where there is a history or a threat of false fire alarms.

HOW IT WORKS

The Euro Stopper consists of a clear, tamperproof, tough polycarbonate cover and frame that retrofits over the break glass call point. When lifted to gain access to the break glass, its optional battery powered integral sounder emits an ear piercing 96 dB (at 3'). Immediate attention is drawn to the area and the prankster will either run or be caught.

ABOUT THE *Glow Guide* & MULTI KIT

The Glow Guide is a unique material embedded in the perimeter of the frame and illuminates in the dark. It creates a radiant glow around the manual call point making it easier to locate in unlit areas. The Multi Kit comes with one Euro Stopper frame embedded with the Glow Guide, 2 colored housing shells (red & green), 1 break seal and 2 label sheets in 13 languages. Available with or without sounder. If you require the product with sounder & relay, sounder & wireless or with sounder, wireless & relay it is recommended to purchase the non-sounder version and then purchase the appropriate accessory to suit your needs.

Key features

General Information

- Protective cover helps prevent malicious or accidental false fire alarms.
- Three year guarantee against breakage of polycarbonate in normal use (one year on electromechanical and electronic components).

Design

- Prevents false alarms, without hindering legitimate operation of a manual call point.
- Glows in the dark.

Construction

- Tough polycarbonate housing.

Installation

- Retrofit over existing device.
- Can accommodate flush or surface mount applications.
- Typical working properties of polycarbonate are -40°C to 121°C (-40° to 250°F).

Electronics

- Available with or without a 96 dB integral sounder, powered by a 3V lithium battery.
- Optional 12-24 VDC powered units.

Options

- One breakseal is supplied with each model. (additional sold separately).
- Other colors available - non Multi Kit versions only.

Remote Wireless Monitoring of Call Points

- You can now be alerted to any vandalism or authorized use of a manual call point in the event of an emergency. Upon activation, the Euro Stopper (when fitted with an optional transmitter and sounder) will emit a localized alarm as well as triggering a receiver providing a visual and audible indication, remotely.

STI Euro Stopper® Multi Kit

MODELS AVAILABLE

- STI-15010ML** Euro Stopper Multi Kit, flush mount without integral sounder
- STI-15C10ML** Euro Stopper Multi Kit, surface mount (32mm spacer) without integral sounder
- STI-15D10ML** Euro Stopper Multi Kit, surface mount (50mm spacer) without integral sounder
- STI-15020ML** Euro Stopper Multi Kit, flush mount with integral sounder
- STI-15C20ML** Euro Stopper Multi Kit, surface mount (32mm spacer) with integral sounder
- STI-15D20ML** Euro Stopper Multi Kit, surface mount (50mm spacer) with integral sounder

Accessories:

- CKE-272-B** Blue Housing Shell
- CKE-272-E** Orange Housing Shell
- CKE-272-G** Green Housing Shell
- CKE-272-K** Black Housing Shell
- CKE-272-R** Red Housing Shell
- CKE-272-W** White Housing Shell
- CKE-272-Y** Yellow Housing Shell
- STI-BS** Break Seals (quantity 10)
- STI-6506** 32mm spacer (comes as standard with 15C10ML & 15C20ML)
- STI-6507** 50mm spacer (comes as standard with 15D10ML & 15D20ML)
- STI-6508** Backplate for Euro Stopper Series
- KIT-EA135** Servicing Pin
- CKE-015-LIT** Sounder Cartridge (comes as standard with 15020ML, 15C20ML & 15D20ML)
- CKE-015** Sounder Cartridge with relay and 12-24 connection
- KIT-319** Remote wiring harness (CKE-015 required when looking to upgrade model)

PLEASE NOTE

When ordering the Euro Stopper Multi Kit you will not receive a fully assembled product.

The Euro Stopper is supplied with red housing shell with operating instructions 'IN CASE OF FIRE – LIFT COVER BREAK GLASS', and green housing shell with operating instruction 'IN CASE OF EMERGENCY - LIFT COVER BREAK GLASS TO OPEN DOOR'. Space above is available to affix language label of choice, achieving dual language operating instructions. Language choices are Czech, Danish, Dutch, Finnish, French, German, Italian, Norwegian, Polish, Portuguese, Russian, Slovakian, Spanish, Swedish and Turkish.

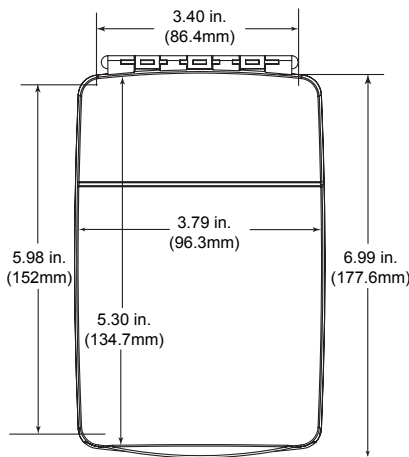

Flush Mount
Front View

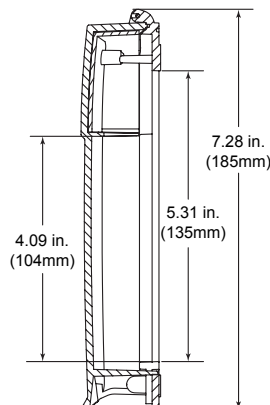

Flush Mount
Side View

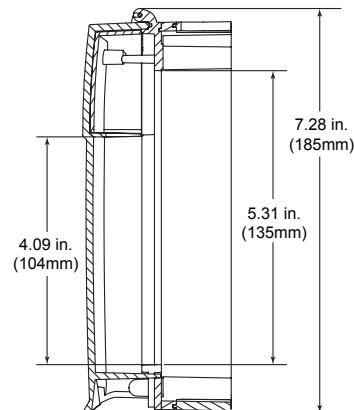

Surface Mount
Side View (32mm Spacer)

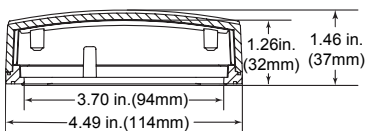

Flush Mount
Side View

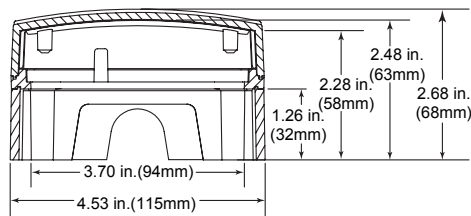

Top View (32mm Spacer)

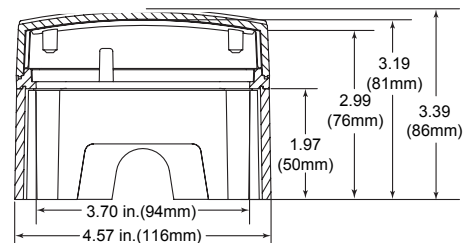

Top View (50mm Spacer) when STI-6507 is purchased



**Safety Technology
International**

2306 Airport Road
Waterford, MI 48327, USA
info@sti-usa.com
www.sti-usa.com
Tel: 248-673-9898

Taylor House
34 Sherwood Rd., Bromsgrove,
Worcs., B60 3DR, England

info@sti-emea.com
www.sti-emea.com
Tel: +44 (0) 1527 520 999

Unit 7A Lockheed Avenue
Airport Business Park
Waterford X91 HWF2 Ireland