



**Safety Technology  
International**

2306 Airport Road  
Waterford • Michigan • 48327-1209  
Phone: 248-673-9898  
E-mail: [info@sti-usa.com](mailto:info@sti-usa.com) • Web: [www.sti-usa.com](http://www.sti-usa.com)

Taylor House • 34 Sherwood Road • Bromsgrove  
Worcestershire • B60 3DR • England  
Tel: +44 (0)1527 520 999  
E-mail: [info@sti-emea.com](mailto:info@sti-emea.com) • Web: [www.sti-emea.com](http://www.sti-emea.com)

Unit 7A • Lockheed Avenue  
Airport Business Park  
Waterford • X91 HWF2 • Ireland  
E-mail: [info@sti-emea.com](mailto:info@sti-emea.com)

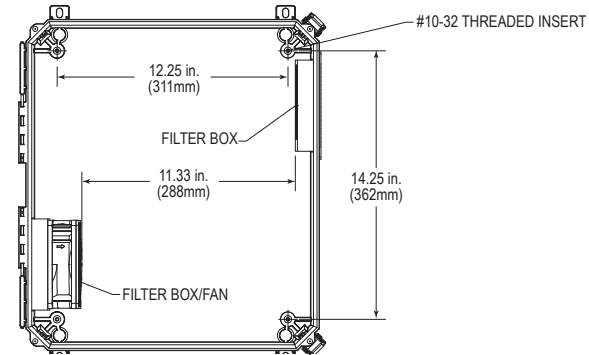
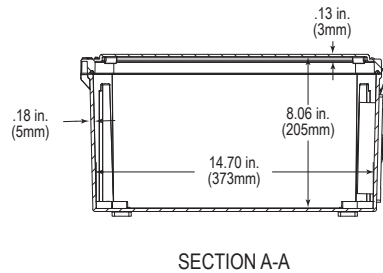
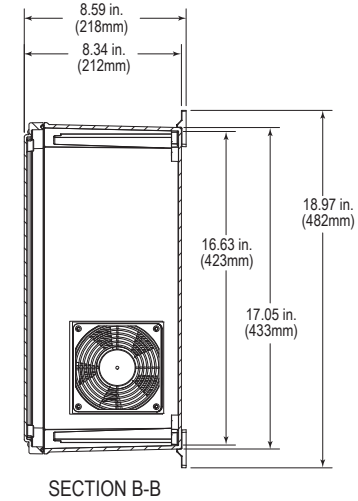
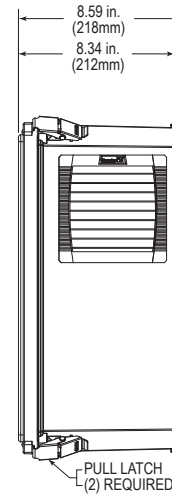
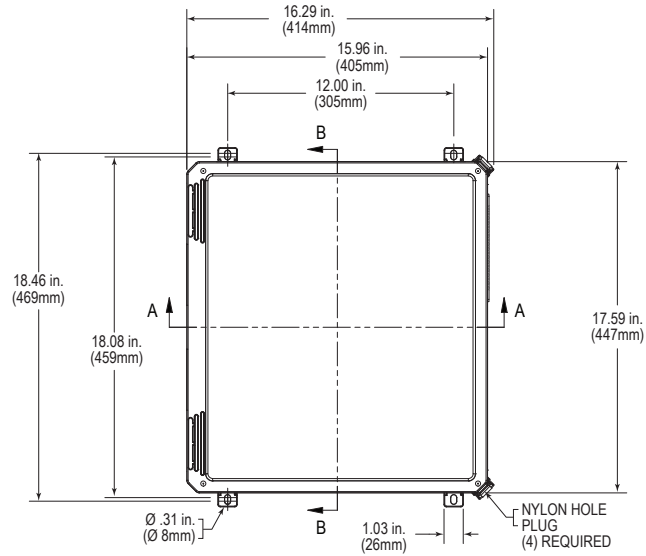

One year limited warranty (from date of purchase).  
See website for details.  
Electronic warranty form at [www.sti-usa.com/wc14](http://www.sti-usa.com/wc14).



USA

**EF161408-x3 ENVIROARMOUR® FIBERGLASS ENCLOSURE  
WITH NEMA 3R FILTER FAN WITH FILTER VENT**

All specifications and information shown were current as of publication and are subject to change without notice.

EF161208x3IS  
SEPT2021

