

2W-BLX/2WT-BLX ADDRESSABLE SMOKE DETECTOR

Installation Guide

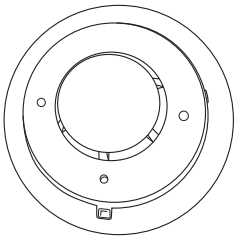

Figure 1: 2W-BLX/2WT-BLX Addressable Smoke Detector

DESCRIPTION

Models 2W-BLX and 2WT-BLX are addressable photoelectric smoke detectors. Both models incorporate a state-of-the-art optical sensing chamber and an advanced microprocessor. These smoke detectors include an addressable single-point module for connection to the LX-Bus™ of XR150/XR550 panels or XF6 Series Fire Control panels.

Compatibility

- XR150/XR550 Series Panels
- XT75 Control Panels
- XF6 Series Fire Control Panels

What is Included?

- One 2W-BLX or 2WT-BLX smoke detector
- 4-wire harness
- Hardware pack



1 ADDRESS THE DETECTOR

Set the two on-board rotary switches to match the last two zone number digits.

Example: On an XR550 panel, to set the detector to zone number 569 on LX-Bus 500, set the left rotary switch (TENS) to **6** and the right rotary switch (ONES) to **9**. See Figure 2.

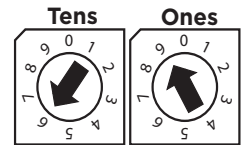

Figure 2: Rotary Switches Set for Zone Address 569

2 INSTALL THE DETECTOR

The detector has a tamper-resistant feature that prevents removal from the mounting base without the use of a tool.

To engage, cut the small plastic tab located on the mounting base (Figure 3), and then install the detector.

To remove the detector head, use a small screwdriver to depress the square tamper release tab on the skirt of the mounting base and turn the detector counterclockwise.

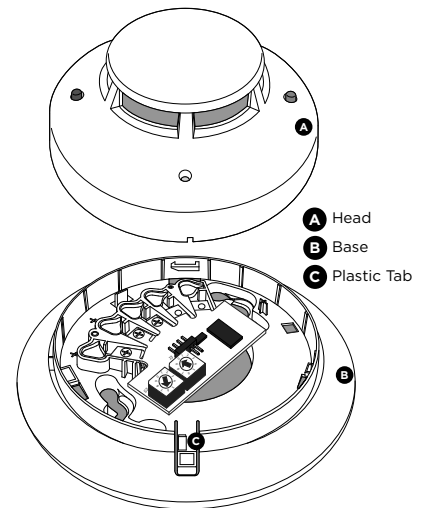

Figure 3: Locking Mount

3 SELECT A LOCATION

Mount the Base:

The detector can be mounted to any of the following surfaces:

- A single gang box
- A 3.5- or 4-inch octagonal box
- A 4-inch square box with a plaster ring
- A ceiling using drywall fasteners

Do Not Install the Detector:

- Where particles of combustion are normally present such as in kitchens or garages (vehicle exhaust) or near furnaces, hot water heaters, or gas space heaters.
- In very cold or very hot areas.
- In wet or excessively humid areas or next to bathrooms with showers.
- In dusty, dirty, or insect-infested areas.
- Near fresh air inlets or returns or excessively drafty areas. These can drive smoke away from the detector.

4 MOUNT THE DETECTOR

Wiring the Detector

1. Pull wire through electrical box, then through the detector's mounting base center opening.
2. Connect the 4-wire harness to the 4-pin header according to the wiring diagram in Figure 4.

Note: For XR150/XR550 panels, tie the red wire (smoke power) to the smoke terminal (SMK) of the panel. For XF6 panels, leave on the LX-Bus™ red.

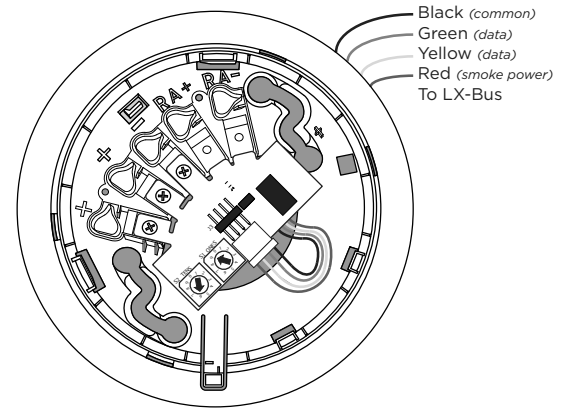

Figure 4: 2W-BLX/2WT-BLX Wiring

Mounting the Detector

1. Place detector on the base and rotate clockwise. The detector will drop into the base and lock into place with a click. See Figure 5.
2. After all the detectors have been installed, apply power to the control panel.

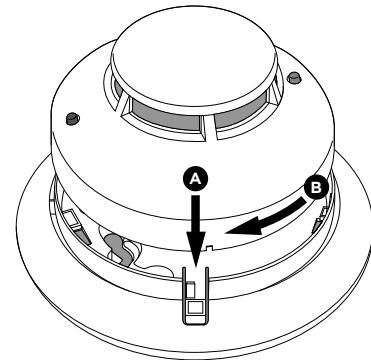

Figure 5: Mounting Detector Head

5 TEST THE DETECTOR

Detectors must be tested after installation and following maintenance. After power up, allow 80 seconds for the detector to stabilize before testing.

Sensitivity Test Switch

1. Insert a small screwdriver or allen wrench (0.18" max.) into the test switch opening located on the detector housing. Push and hold (See Figure 6).
2. If the detector is within the listed sensitivity limits, the detector's Red LED should turn on within five seconds.
3. To measure the detector's sensitivity, use the System Sensor i³ Series Model SENS-RDR Infrared Sensitivity Reader® tool.

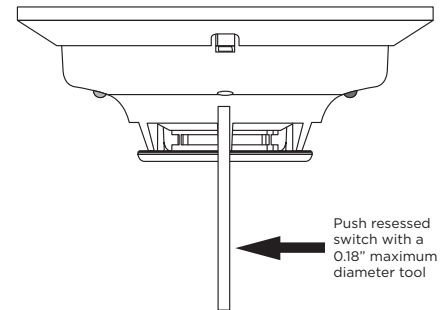

Figure 6: Sensitivity Testing the 2W-BLX/2WTBLX

Smoke Entry Test

Hold a smoldering stick or cotton wick at the side of the detector and gently blow through the detector until it alarms.

Caution: Be sure to properly extinguish the smoke source after testing.

Direct Heat Method (Model 2WT-BLX only)

Direct the heat of a 1000-1500 watt hair dryer toward either of the thermistors. Thermistors are located on each side of the screen/sensing chamber. Hold the heat source about 12 inches from the detector to avoid damage to the plastic.

Note: For the above tests, the detector will reset only after a Sensor Reset is performed.

If the detector fails any of the above tests, check the wiring and clean the detector as outlined in the Maintenance Section. If the detector still fails, it should be replaced.

ADDITIONAL INFORMATION

Location Advice

Consult the Local Authority Having Jurisdiction (AHJ) and NFPA 72 for specific installation information about smoke detector spacing, placement, location, and special applications.

Maintenance and Cleaning

This detector must be tested and maintained regularly following NFPA 72 requirements. At a minimum, cleaning should be performed annually.

Before performing maintenance on the detector, notify the proper authorities that maintenance is being performed and the system will be temporarily out of service. Disable the circuit undergoing maintenance to prevent any unwanted alarms. Power must be removed from the detector before performing maintenance of any kind.

1. Remove the detector cover by turning counterclockwise.
2. Vacuum the cover or use canned air to remove any dust or debris.
3. Remove the top half of the screen/sensing chamber by lifting straight up (See Figure 7.)
4. Vacuum or use canned air to remove any dust particles that are present on both chamber halves.
5. Replace the top half of the screen/sensing chamber by aligning the arrow on the screen/sensing chamber with the arrow on the housing. Press down firmly until the screen/sensing chamber is fully seated.
6. Replace the detector cover by placing it over the screen/sensing chamber and turning it clockwise until it snaps into place.
7. Reinstall the detector and test. (See Test the Detector.)

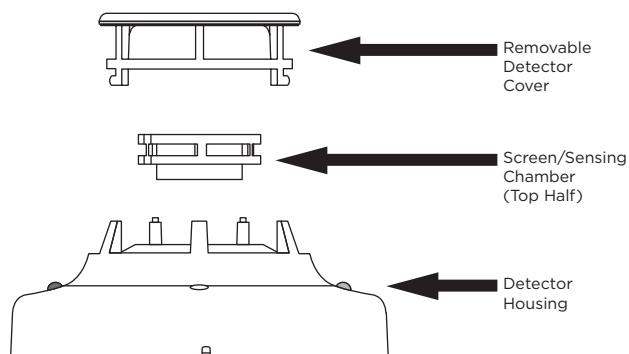

Figure 7: 2W-BLX/2WT-BLX Exploded View

Wiring Specifications

When planning an LX-Bus installation, keep in mind the following specifications:

1. DMP recommends using 18-gauge unshielded wire for all LX-Bus circuits. Do Not use twisted pair or shielded wire for LX-Bus circuits. To maintain auxiliary power integrity when using 18-gauge wire do not exceed 1,000 feet. To increase the wire length or to add devices, install an additional power supply.
2. Maximum distance for any one circuit (length of wire) is 2,500 feet regardless of the wire gauge. This distance can be in the form of one long wire run or multiple branches with all wiring totaling no more than 2,500 feet. As wire distance from the panel increases, DC voltage on the wire decreases.
3. Maximum number of devices per 2,500 feet circuit is 40.
4. Maximum voltage drop between the panel (or auxiliary power supply) and any device is 2.0 VDC. If the voltage at any device is less than the required level, add an auxiliary power supply at the end of the circuit. When voltage is too low, the devices cannot operate properly.

For additional information refer to the 710 Installation Sheet (LT-0310) and/or the LX-Bus/Keypad Bus Wiring Application Note (LT-2031).

Single Point Addressable

A factory-mounted, addressable single-point zone expander is integrated in the base of the smoke detector. The included 4-wire harness allows a direct connection to the LX-Bus of XR150/XR550 Series and XF6 Series panels. The integrated zone expander reports to the panel as a single zone. See Addressing the 2W-BLX and 2WT-BLX.

A Green LED is included on the integrated zone expander PCB which flashes every 2 seconds to confirm device polling.

Fixed Temperature Thermal Detector

The Model 2WT-BLX features a restorable, built-in, fixed temperature thermal detector and is capable of sensing a temperature higher than 135°F. If the detector senses a higher temperature than 135°F, the Red LED latches on, and an alarm condition is sent to the control panel.

ADDITIONAL INFORMATION (CONTINUED)

Built-In Drift Compensation

The detector automatically adjusts its sensitivity back to the factory setting when it becomes more sensitive due to contaminants settling in its chamber. In order for this feature to work properly, the chamber must never be opened while power is applied to the smoke detector. This includes cleaning, maintenance, or screen replacement.

LED Operation

After power-up has completed and the detector is functioning normally within its listed sensitivity range, the Green LED blinks once every five seconds.

If the detector needs maintenance because its sensitivity has shifted outside the limits, the Red LED blinks once every five seconds. See Table 1.

The LED indication must not be used in lieu of the tests specified under Testing.

ANSI/UL 268

Smoke detectors are not to be used with detector guards unless the combination has been evaluated and found suitable for that purpose.

	GREEN LED	RED LED
Power-Up	Blink 10 seconds	Blink 10 seconds
Normal (Standby)	Blink 5 seconds	—
Out of Sensitivity	—	Blink 5 seconds
Alarm	—	Solid

Table 1: Detector LED Modes

2W-BLX/2WT-BLX ADDRESSABLE SMOKE DETECTOR

Specifications

Operating Voltage	9 – 15 Vdc
Standby Current	15 mA
Alarm Current	36 mA
Maximum Ripple	30% (V) peak to peak
Operating Temperature (Ambient Room)	
2W-BLX	32°F to 120°F
2WT-BLX	32°F to 100°F
Operating Humidity Range	0 to 95% RH non-condensing
Heat Sensor (2WT-BLX Only)	135°F
Power Up Time	80 seconds

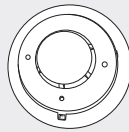

Sensitivity Photoelectric	1-4%/ft.
Detector Dimensions	
Diameter	5.3 inches
Height	2.0 inches
Weight	6.3 ounces

Ordering Information

2W-BLX	Photoelectric smoke detector
2WT-BLX	Photoelectric smoke detector with fixed-temperature thermal detector

Certifications

California State Fire Marshal (CSFM)
Underwriters Laboratories (UL) Listed
ANSI/UL 268 Smoke-Automatic Fire Detectors 7th Edition



Designed, engineered, and manufactured in Springfield, MO using U.S. and global components.

LT-1364 1.03 25092
©2025

INTRUSION • FIRE • ACCESS • NETWORKS

2500 North Partnership Boulevard
Springfield, Missouri 65803-8877
800.641.4282 | DMP.com